

COMPACT INVERTER SERIES

J1000



EN

DE

ES

FR

IT

J1000
J1000
J1000

J1000

THE J-TYPE YASKAWA INVERTER DRIVE TECHNOLOGY

Contents

- ▶ **Page 2**
Experience & Innovation
A leader in Inverter Drives technology
- ▶ **Page 3**
Features & Functions
- ▶ **Page 4**
Specifications
- ▶ **Page 5**
Connection Diagram
- ▶ **Page 6**
Dimensions
- ▶ **Page 7**
Ratings & Type Descriptions

Experience & Innovation

For more than 90 years YASKAWA has been manufacturing and supplying mechatronic products for machine building and industrial automation.

A leader in Inverter Drives technology

Extensive research and development has allowed YASKAWA to remain at the forefront of motion control and automation technology. This technological leadership has helped to modernise industries such as mining, steel, pulp and paper, chemical, automotive, packaging, machine tool and semiconductor.

Its standard products as well as tailor-made solutions are famous and have a high reputation for outstanding quality and durability.

The famous YASKAWA reliability is now available in an even smaller and more powerful unit.

J1000 is fully capable of efficient performance and energy saving, handling variable speed needs in compact applications.



The J1000 cutting-edge features such as:

- ▶ V/f Control
- ▶ Plug'n Play installation function
- ▶ Over-Excitation Braking
- ▶ Easy parameter programming and controller functions
- ▶ Braking Chopper
- ▶ Heavy duty / normal duty rating
- ▶ International standards

YASKAWA
J1000



Features & Functions

Focus on application

Customer orientation and application focus – two attributes of machine equipment YASKAWA offers with its new J1000 compact inverter drive series.

The J1000 meets all automation requirements for compact applications with variable speed operation and energy saving characteristics. A wide range of useful functions upgrade your machine and offer great potentials.

The concept of small size and easy handling with the famous YASKAWA reliability makes the J1000 an alternative in the drive market not only cost wise.

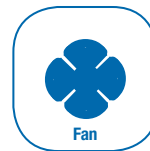
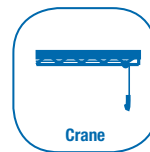
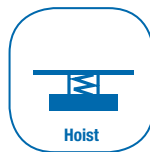
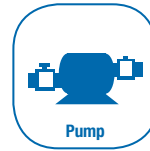
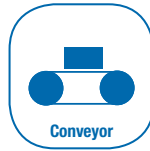

YASKAWA J1000 Features & Functions

Performance

- ▶ Compact Design – Small design and side-by-side mounting reduce installation space and costs.
- ▶ Stall Prevention Functions – Stall prevention ensures stable operation during momentary power loss, change of load or power supply.
- ▶ International Standards – RoHS, CE, cUL, UL compliance.
- ▶ High Torque Performance – Detects load and automatically adjusts torque regardless the actual speed conditions.
- ▶ Digital Operator – 5 digit display, 8 keys on the operator as well as Verify Function for changed parameter values.

Options

- ▶ Parameter Copy Unit
- ▶ Optional LED Remote Operator
- ▶ Serial Communication Option – Compatible with RS-422/485 Interface for MEMOBUS communication.
- ▶ Speed Potentiometer

Functions

- ▶ Easy Set-Up Functions – Enables quick installation and operation.
- ▶ Over-Excitation Braking – For quick deceleration without external braking resistor.
- ▶ Maintenance monitor informs in advance about recommended maintenance for cooling fan and electrolytic capacitors.

- ▶ Small Design – Big Power: 150% overload in heavy duty service is possible. For applications with low overload requirements the drive can be operated with 120% overload in normal duty service. Consequently you can use a drive of smaller size to do the work of a bigger one.
- ▶ Tough Operation – Power-Loss-Ride-Through and Fault Restart Functions ensure continuous running of the motor.
- ▶ Drive Wizard Plus – Free of charge parameter set-up and maintenance tool.

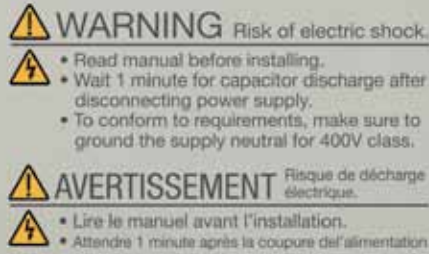

Specifications

| | | Specifications |
|--|---|--|
| Control Characteristics | Control methods | V/f Control |
| | Frequency Control Range | 0.01 to 400 Hz |
| | Frequency Accuracy (Temperature Fluctuation) | Digital input: within $\pm 0.01\%$ of the max. output frequency (-10°C to $+50^{\circ}\text{C}$) |
| | | Analog input: within $\pm 0.5\%$ of the max. output frequency ($25^{\circ}\text{C} \pm 10^{\circ}\text{C}$) |
| | Frequency Setting Resolution | Digital input: 0.01 Hz |
| | | Analog input: 1/1000 of max. frequency |
| | Output Frequency Resolution | $1/2^{20}$ x Maximum output frequency (E1–04) |
| | Frequency Setting Signal | Main frequency reference: 0 to +10 Vdc (20 k Ω), 4 to 20 mA (250 Ω), 0 to 20 mA (250 Ω) |
| | Starting Torque | 150% / 3 Hz |
| | Speed Control Range | 1:20 |
| | Accel/Decel Time | 0.0 to 6000.0 s (4 selectable settings of independent acceleration and deceleration time) |
| | Braking Torque | ① Short-time decel torque*1: over 150% for 0.1/0.2 kW motors, over 100% for 0.4/ 0.75 kW motors, over 50% for 1.5 kW motors, and over 20% for 2.2 kW and above motors. |
| ② Continuous regen. torque: approx. 20% (approx. 125% with dynamic braking resistor option*2: 10% ED, 10 s, internal braking transistor) | | |
| V/f Characteristics | User-set programmable V/f preset patterns possible | |
| Main Control Functions | Momentary power loss ride-thru, Speed search, Multi-Step Speed (max. 9 steps), Accel/decel time switch, S-curve accel/decel, 3-wire sequence, Cooling fan on/off, Slip compensation, Torque compensation, Frequency jump, Upper/lower limits for frequency reference, DC injection braking at start and stop, Overexcitation braking, Fault restart ... | |
| Protection Function | Motor Protection | Motor overheat protection based on output current |
| | Momentary Overcurrent Protection | Drive stops when output current exceeds 200% of Heavy Duty Rating |
| | Overload Protection | Drive stops after 60 s at 150% of rated output current (Heavy Duty Rating)*3 |
| | Overvoltage Protection | 200 V class: Stops when DC bus exceeds approx. 410 V |
| | | 400 V class: Stops when DC bus exceeds approx. 820 V |
| | Undervoltage Protection | Stops when DC bus voltage falls below the following levels: |
| | | 190 V (3-phase 200 V), 160 V (single-phase 200 V), 380 V (3-phase 400 V), 350 V (3-phase 380 V) |
| | Momentary Power Loss Ride-Thru | Stops after approx. 15 ms (default). |
| | Heatsink Overheat Protection | Protected by thermistor |
| | Braking Resistance Overheat Protection | Overheat input signal for braking resistor (optional ERF-type, 3% ED) |
| Stall Prevention | Separate settings allowed during acceleration and during run. Enable/disable only during deceleration. | |
| Ground Fault Protection | Protected by electronic circuit*4 | |
| Charge LED | Charge LED remains lit until DC bus falls below approx. 50 V | |
| Operating Environment | Area of Use | Indoors |
| | Ambient Temperature | -10 to $+50^{\circ}\text{C}$ (IP20 open chassis), -10 to $+40^{\circ}\text{C}$ (NEMA Type 1) |
| | Humidity | 95 RH% or less (no condensation) |
| | Storage Temperature | -20 to $+60^{\circ}\text{C}$ (short-term temperature during transportation) |
| | Altitude | Max. 1000 m (output derating of 1% per 100 m above 1000 m, max. 3000 m) |
| | Shock | 10 to 20 Hz (9.8 m/s ²) max., 20 to 55 Hz (5.9 m/s ²) max. |
| Standards | CE, UL, cUL, RoHS | |
| Protection Design | IP20 open-chassis, NEMA Type 1 enclosure (option) | |

*1 Momentary average deceleration torque refers to the torque required to decelerate the motor (uncoupled to the load) from the rated motor speed down to zero in the shortest time.

*2 Parameter L3-04 should be disabled when a Braking Resistor or Braking Resistor Unit is connected.

*3 Overload protection may be triggered at lower levels if output frequency is below 6 Hz.

*4 Protection may not be provided under the following conditions as the motor windings are grounded internally during run:

- Low resistance to ground from the motor cable or terminal block.
- Drive already has a short-circuit when the power is turned on.

Connection Diagram

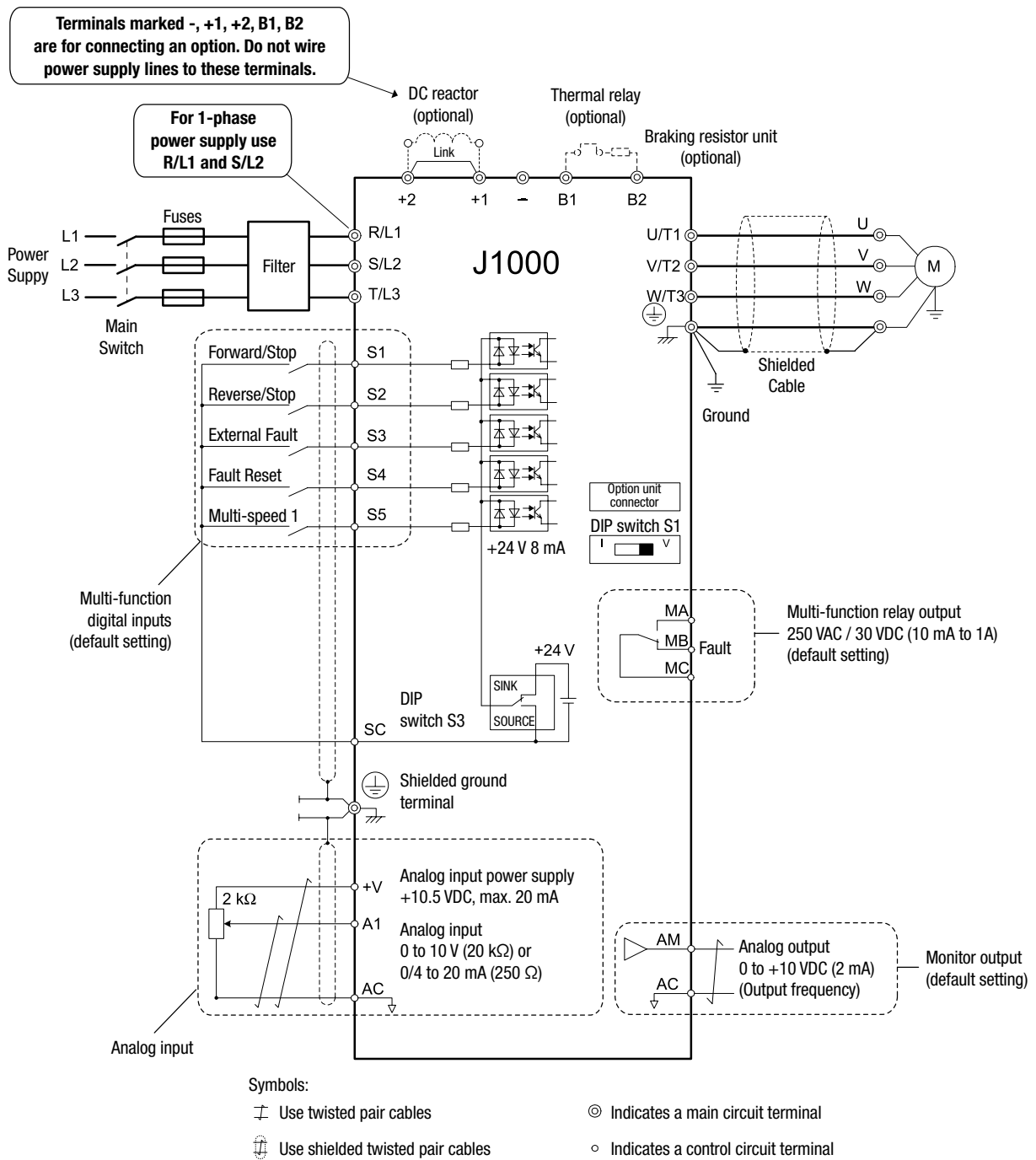



Dimensions

Enclosures

Standard J1000 uses IP20 design.

NEMA 1 kits are available to convert the standard IP20 design to a NEMA Type 1 enclosure rating.

Open-Chassis [IP20]

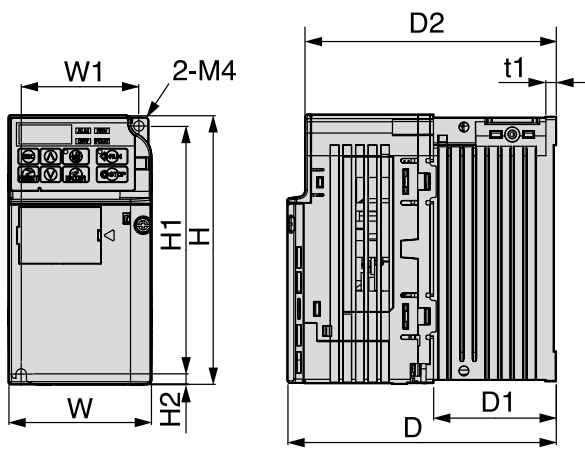

Fig. 1

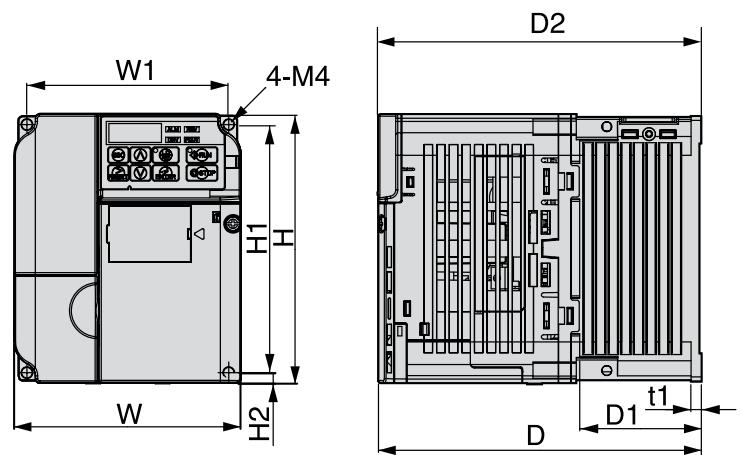
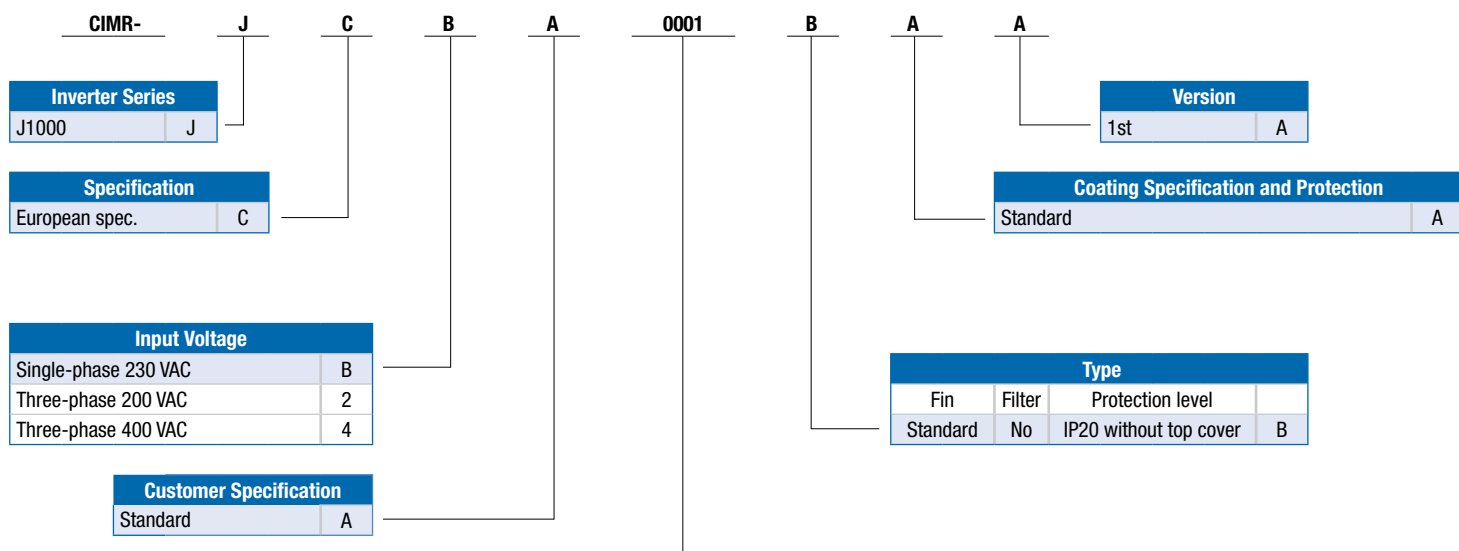

Fig. 2

| Voltage Class | Drive Model CIMR-JC□ | Figure | Dimensions in mm | | | | | | | | | | Weight (kg) | Cooling |
|-----------------------------|-------------------------|--------|------------------|-----|-------|-----|-----|-------|------|-------|----|-----|----------------|---------|
| | | | W | H | D | W1 | H1 | H2 | D1 | D2 | t1 | | | |
| Three-Phase 200 V Class | 2A0001B | 1 | 68 | 128 | 76 | 56 | 118 | 5 | 6.5 | 67.5 | 3 | 0.6 | Self-cooled | |
| | 2A0002B | | 68 | 128 | 76 | 56 | 118 | 5 | 6.5 | 67.5 | 3 | 0.6 | | |
| | 2A0004B | | 68 | 128 | 108 | 56 | 118 | 5 | 38.5 | 99.5 | 5 | 0.9 | | |
| | 2A0006B | 2 | 68 | 128 | 128 | 56 | 118 | 5 | 58.5 | 119.5 | 5 | 1.1 | Fan cooled | |
| | 2A0010B | | 108 | 128 | 129 | 96 | 118 | 5 | 58 | 120.5 | 5 | 1.7 | | |
| | 2A0012B | | 108 | 128 | 137.5 | 96 | 118 | 5 | 58 | 129 | 5 | 1.7 | | |
| 2A0020B | 140 | 128 | 143 | 128 | 118 | 5 | 65 | 134.5 | 5 | 2.4 | | | | |
| Single-Phase 200 V Class | BA0001B | 1 | 68 | 128 | 76 | 56 | 118 | 5 | 6.5 | 67.5 | 3 | 0.6 | Self-cooled | |
| | BA0002B | | 68 | 128 | 76 | 56 | 118 | 5 | 6.5 | 67.5 | 3 | 0.6 | | |
| | BA0003B | | 68 | 128 | 118 | 56 | 118 | 5 | 38.5 | 109.5 | 5 | 1.0 | | |
| | BA0006B | 2 | 108 | 128 | 137.5 | 96 | 118 | 5 | 58 | 129 | 5 | 1.7 | Fan cooled | |
| | BA0010B | | 108 | 128 | 154 | 96 | 118 | 5 | 58 | 145.5 | 5 | 1.8 | | |
| Three-Phase 400 V class | 4A0001B | 2 | 108 | 128 | 81 | 96 | 118 | 5 | 10 | 72.5 | 5 | 1.0 | Self-cooled | |
| | 4A0002B | | 108 | 128 | 99 | 96 | 118 | 5 | 28 | 90.5 | 5 | 1.2 | | |
| | 4A0004B | | 108 | 128 | 137.5 | 96 | 118 | 5 | 58 | 129 | 5 | 1.7 | | |
| | 4A0005B | | 108 | 128 | 154 | 96 | 118 | 5 | 58 | 145.5 | 5 | 1.7 | Fan cooled | |
| | 4A0007B | | 108 | 128 | 154 | 96 | 118 | 5 | 58 | 145.5 | 5 | 1.7 | | |
| | 4A0009B | | 108 | 128 | 154 | 96 | 118 | 5 | 58 | 145.5 | 5 | 1.7 | | |
| | 4A0011B | | 140 | 128 | 143 | 128 | 118 | 5 | 65 | 134.5 | 5 | 2.4 | | |



Ratings & Type Descriptions



| Voltage class | | 200 V | | | | | | |
|------------------------|---|---|-------|-----------|-------|-------|--------|--------|
| Inverter Model | Three Phase Inverter CIMR-JC2A | 0001 | 0002 | 0004 | 0006 | 0010 | 0012 | 0020 |
| | Single Phase*1 Inverter CIMR-JCBA | 0001 | 0002 | 0003 | 0006 | 0010 | – | – |
| Inverter output | Motor output kW at normal duty*2 | 0.2 | 0.4 | 0.75 | 1.1 | 2.2 | 3.0 | 5.5 |
| | Motor output kW at heavy duty*2 | 0.1 | 0.2 | 0.4 | 0.75 | 1.5 | 2.2 | 4.0 |
| | Rated output current at normal duty [A]*3 | 1.2 | 1.9 | 3.5 (3.3) | 6.0 | 9.6 | 12.0 | 19.6 |
| | Rated output current at heavy duty [A] | 0.8*5 | 1.6*5 | 3*5 | 5.0*5 | 8.0*6 | 11.0*6 | 17.5*6 |
| | Overload | 120% for 60 sec at normal duty, 150% for 60 sec at heavy duty from inverter rated output current | | | | | | |
| | Rated output power*4 at normal duty [kVA]*3 | 0.5 | 0.7 | 1.3 | 2.3 | 3.7 | 4.6 | 7.5 |
| | Rated output power*4 at heavy duty [kVA] | 0.3 | 0.6 | 1.1 | 1.9 | 3.0 | 4.2 | 6.7 |
| Inverter input | Max. output voltage | Three-phase power supply: three-phase 200 to 240 V (relative to input voltage) Single-phase power supply: three-phase 200 to 240 V (relative to input voltage) | | | | | | |
| | Max. output frequency | 400 Hz | | | | | | |
| | Rated input voltage | Three-phase 200 to 240 V +10%/-15% , Single-phase 200 to 240 V +10%/-15% | | | | | | |
| | Rated input frequency | 50/60 Hz, ±5% | | | | | | |

*1 Drives with a single-phase power supply input have three-phase output. Single-phase motors cannot be used.
 *2 The motor capacity (kW) refers to a YASKAWA 4-pole, 60 Hz, 200 V motor. The rated output current of the drive output amps should be equal to or greater than the motor rated current.
 *3 This value assumes a carrier frequency of 2 kHz to Swing PWM. Increasing the carrier frequency requires a reduction in current.
 *4 Rated output capacity is calculated with a rated output voltage of 220 V.
 *5 This value assumes a carrier frequency of 10 kHz. Increasing the carrier frequency requires a reduction in current.
 *6 This value assumes a carrier frequency of 8 kHz. Increasing the carrier frequency requires a reduction in current.

| Voltage class | | 400 V | | | | | | |
|------------------------|---|--|------|------|------|------|------|------|
| Inverter Model | Three Phase Inverter CIMR-JC4A | 0001 | 0002 | 0004 | 0005 | 0007 | 0009 | 0011 |
| | | | | | | | | |
| Inverter output | Motor output kW at normal duty*1 | 0.4 | 0.75 | 1.5 | 2.2 | 3.0 | 3.7 | 5.5 |
| | Motor output kW at heavy duty*1 | 0.2 | 0.4 | 0.75 | 1.5 | 2.2 | 3.0 | 3.7 |
| | rated output current at normal duty*2 [A] | 1.2 | 2.1 | 4.1 | 5.4 | 6.9 | 8.8 | 11.1 |
| | rated output current at heavy duty*3 [A] | 1.2 | 1.8 | 3.4 | 4.8 | 5.5 | 7.2 | 9.2 |
| | Overload | 120% for 60 sec at normal duty, 150% for 60 sec at heavy duty from inverter rated output current | | | | | | |
| | Rated output power*4 at normal duty*2 [kVA] | 0.9 | 1.6 | 3.1 | 4.1 | 5.3 | 6.7 | 8.5 |
| | Rated output power*4 at heavy duty*3 [kVA] | 0.9 | 1.4 | 2.6 | 3.7 | 4.2 | 5.5 | 7.0 |
| Inverter input | Max. output voltage | Three-phase 380 to 480 V (proportional to input voltage) | | | | | | |
| | Max. output frequency | 400 Hz | | | | | | |
| | Rated input voltage | Three-phase 380 to 480 V +10%/-15% | | | | | | |
| | Rated input frequency | 50/60 Hz +/-5% | | | | | | |

*1 The motor capacity (kW) refers to a YASKAWA 4-pole, 60 Hz, 400 V motor. The rated output current of the drive output amps should be equal to or greater than the motor rated current.
 *2 This value assumes a carrier frequency of 2 kHz to Swing PWM. Increasing the carrier frequency requires a reduction in current.
 *3 This value assumes a carrier frequency of 8 kHz. Increasing the carrier frequency requires a reduction in current.
 *4 Rated output capacity is calculated with a rated output voltage of 440 V.



YASKAWA Europe GmbH

Drives & Motion Division
Hauptstr. 185
65760 Eschborn
Germany

+49 6196 569-300
info@yaskawa.eu.com
www.yaskawa.eu.com

